

Project:	Type:
Prepared By:	Date:

Direct light down with a dome reflector or to the side with an angle reflector. Highly reflective surfaces over heavy gauge aluminum base. Field installable with 4 screws provided with fixture.

Color: N/A

Weight: 2.0 lbs

Technical Specifications

Construction

Reflectors:

Heavy gauge aluminum with highly reflective white epoxy powder coat finish.

Other

Country of Origin:

Designed by RAB in New Jersey and assembled in the USA by RAB's IBEW Local 3 workers.

Buy American Act Compliant:

This product is a COTS item manufactured in the United States, and is compliant with the Buy American Act.

Recovery Act (ARRA) Compliant:

This product complies with the 52.225-21 "Required Use of American Iron, Steel, and Manufactured Goods-- Buy American Act-- Construction Materials (October 2010).

Trade Agreements Act Compliant:

This product is a COTS item manufactured in the United States, and is compliant with the Trade Agreements Act.

GSA Schedule:

Suitable in accordance with FAR Subpart 25.4.

Dimensions

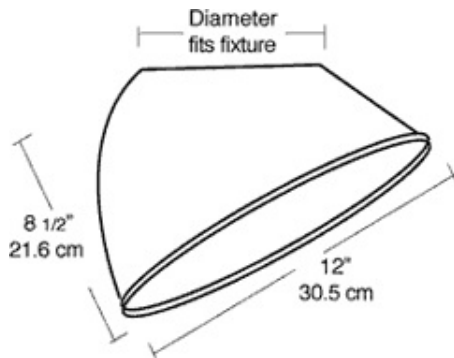

Features

- Accessory reflectors and exit signs available
- Cast aluminum junction box also serves as a hanger box for pendant fixtures
- Heavy gauge die formed aluminum
- Reflectors with white polyester powder finish