



Sleek design 500 Watt Quartz flood with rounded back and fins for superior heat dissipation. Vandalproof stainless steel locking clip. Gold plated socket contacts and 250°C Teflon coated wires for extended lamp life. Lamp supplied.

Color: Bronze

Weight: 3.1 lbs

Project:	Type:
Prepared By:	Date:

Lamp Info		Ballast Info	
Type:	T3	Type:	N/A
Watts:	500W	120V:	N/A
Shape/Size:	N/A	208V:	N/A
Base:	N/A	240V:	N/A
ANSI:	N/A	277V:	N/A
Hours:	2,000	Input Watts:	500W
Lamp Lumens:	11,000		
Efficacy:	22 LPW		

Technical Specifications

Listings

UL Listing:

Suitable for wet locations. Suitable for mounting within 1.2m (4ft) of the ground.

Construction

Housing:

Die cast aluminum, 1/2" NPS threaded arm with locking swivel fits all standard mounting covers.

Lens Gasket:

High temperature silicone gasket stays in place during relamping.

Reflector:

Semi-specular anodized aluminum.

Lens:

Thermal, tempered, shock resistant glass.

Finish:

Our environmentally friendly polyester powder coatings are formulated for high-durability and long-lasting color, and contains no VOC or toxic heavy metals.

Electrical

Sockets:

Porcelain RSC base sockets with gold plated spring loaded contacts and strain relieved 250° C Teflon insulated wires.

Dimensions

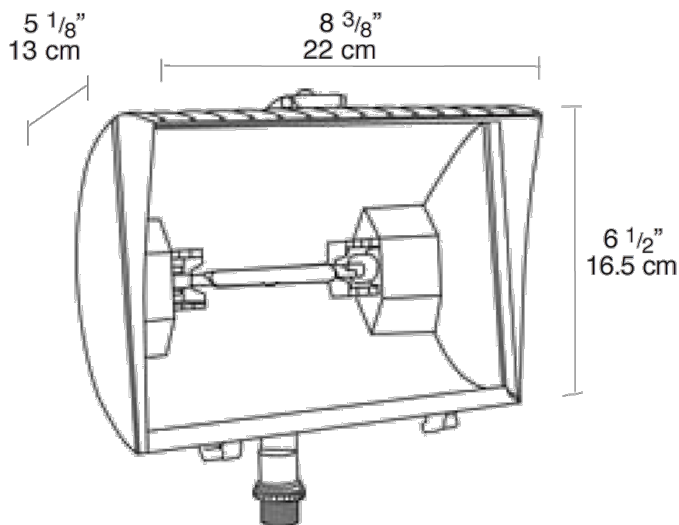

Features

- Silicone gasket remains in place during relamping
- 5mm thick, tempered glass lens
- High quality 130 volt (for extended life) Quartz Halogen lamp
- Stainless steel external hardware
- Stainless steel clip with Vandal proof screw capability
- Integra hood glare shield for friendly lighting when properly aimed
- Fins for heat dissipation and extended lamp life