



Flat or round bottom wire clamp guard made of No. 8 gauge steel rod welded to a clamping band. Guard is protected from corrosion by a baked silver gray polyester powder finish.

Color: Silver gray

Weight: 0.6 lbs

Project:	Type:
Prepared By:	Date:

Technical Specifications

Listings

UL Listing:

Suitable for wet locations when used with RAB Vapor proof fixtures.

Other

Die Cast Guards:

One pieced die cast aluminum. Set screw locks guard in place. Also a wire clamp guard is available.

Country of Origin:

Designed by RAB in New Jersey and assembled in Taiwan.

Trade Agreements Act Compliant:

This product is a product of Taiwan and a "designated country" end product that complies with the Trade Agreements Act.

GSA Schedule:

Suitable in accordance with FAR Subpart 25.4.

Construction

Wire Clamp Guards:

No. 8 gauge steel wire rod welded to clamping band with captive clamping screw.

Dimensions

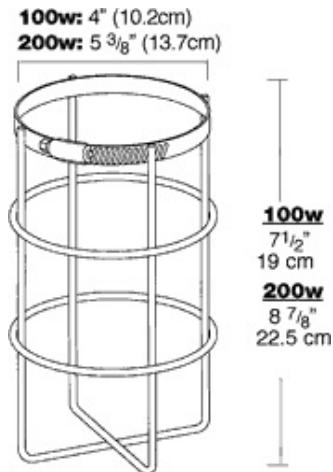

Features

- Set screw locks guard in place
- Machined threads for smooth running fit on Vaporproof fixtures
- Heavy, one-piece aluminum die casting
- Captive clamping screw won't fall out
- Threaded aluminum ring secures reflector to fixture