

NUVO LIGHTING

Product Specification



60-3307

Empire Mini Pendant with Hang–Straight Canopy
Brushed Nickel / Frosted Glass
(1) 13W CFL / GU24 base / 2700K Included

Dimensions:

Width: 7"

Height: 51" Adjustable

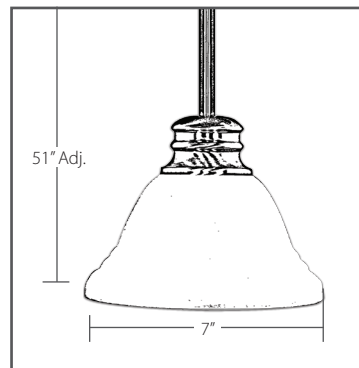

NUVO[®]

LIGHTING

Another innovative Satco Brand
www.nuvolighting.com



National Toll-Free: 1.800.43.SATCO (1.800.437.2826) www.satco.com
Corporate Offices: 110 Heartland Blvd., Brentwood, NY 11717 800.437.2826 631.243.2022 Fax 631.243.2027
Distribution Centers: New York, Florida, Texas, Washington, California, Puerto Rico



© Copyright 2012, SATCO Products, Inc. NU1123